

OPTIMAL SIZING OF HYBRID RENEWABLE ENERGY SYSTEMS FOR ALGERIAN MUNICIPALITIES: AN INTEGRATED HOMER PRO AND MATHEMATICAL FRAMEWORK

Kherbouche Djamila¹ Sebbagh Hafidha¹ Ghomri Amina*^{1,2} Lassouani Fatiha¹ Missoum Nouredine^{2,3}

¹Ecole Supérieure en Sciences Appliquées de Tlemcen (ESSA), B. P.165 belhorizon 13000 Tlemcen. Algeria.

²Laboratory of Natural Products and Bioactives- LASNABIO, University of Tlemcen. B. P. 119, 13000 Tlemcen. Algeria.

³Faculty of Technology, Hassiba Benbouali University of Chlef, Algeria

Received: 14/10/2025 Accepted: 04/01/2025 Published: 15/05/2026

ABSTRACT

Algeria's commitment to a 27% renewable share in national electricity generation by 2030 places substantial pressure on local and municipal authorities to operationalise clean energy transitions at the sub-national level. This paper presents a comprehensive techno-economic and mathematical analysis of a hybrid renewable energy system (HRES) designed for a representative Algerian municipality. Using HOMER Pro simulation software, we evaluate four system configurations namely, photovoltaic /diesel/ battery (PV-DG-B), photovoltaic/ wind/ battery (PV-WT-B), photovoltaic/wind/diesel/battery (PV-WT-DG-B), and a grid-connected PV hybrid under real climatic conditions of the semi-arid Algerian highlands. Optimal sizing is further validated through deterministic mathematical models, including net present cost (NPC) minimisation, levelised cost of energy (LCOE) derivation, and a multi-objective optimisation framework integrating reliability constraints (LPSP \leq 2%) and carbon reduction targets. Our obtained results indicate that the PV-WT-DG-B configuration achieves the lowest NPC of USD 412,800, an LCOE of 0.089 USD/kWh, a renewable fraction of 87.4%, and a CO₂ reduction of 78.3 tonnes/year compared to a diesel-only baseline. Our study connects physical energy findings to local governance discourse, examining how municipal administrations communes (APC) and state-level energy offices can leverage such modelling to formulate data-driven energy action plans (EAPs) in alignment with Algeria's National Renewable Energy Programme (PNER) and the Sustainable Development Goals (SDGs 7 and 13). Our study contributes to the emerging discourse on energy decentralisation and green municipal governance by providing evidence-based insights for local policymaking in North African settings.

Keywords: hybrid renewable energy system; HOMER Pro; techno-economic optimisation; LCOE; NPC; local self-government; energy transition.

1. Introduction

Algeria stands at a pivotal juncture in its energy history. With over 3,000 hours of annual sunshine, a vast Saharan plateau offering sustained wind corridors, and a rapidly growing population projected to exceed 53 million by 2030, the country possesses both the solar irradiance potential and the socio-economic imperative to accelerate its transition toward renewable energy (Stambouli, et al 2012). Yet the translation of this macroeconomic and climatic potential into tangible local energy systems remains a critical governance challenge. Algeria's electricity grid still relies predominantly on natural gas accounting for approximately 96% of the 21,400 MW of installed capacity leaving sub-national authorities with limited renewable infrastructure (MEI, 2023).

The Algerian government has formalised its ambitions through the National Programme for the Development of Renewable Energies (PNER), targeting 22 GW of renewable capacity by 2030, of which 13.5 GW will come from solar photovoltaic (PV), 5 GW from wind, and the remainder from concentrated solar power and biomass (Ministry of Energy, 2020). These targets are ambitious in their scale but remain largely driven by centralised planning mechanisms. The challenge of decentralisation of empowering communes (assemblées populaires communales, APC) and states to design, finance, and operate local renewable projects has received insufficient scholarly attention, particularly in the context of North Africa's political economy.

Within this governance vacuum, hybrid renewable energy systems (HRES) offer a technically and economically viable pathway for municipal energy autonomy. A HRES combines two or more electricity generation technologies typically solar PV, wind turbines (WT), diesel generators (DG), and battery storage to supply local loads reliably, cost-effectively, and with reduced emissions. However, the design and sizing of such systems require sophisticated techno-economic tools. Among these, HOMER Pro (Hybrid Optimisation Model for Multiple Energy Resources), developed by the National Renewable Energy Laboratory (NREL), has emerged as the industry standard for feasibility analysis, optimisation, and sensitivity studies in off-grid and grid-connected contexts (Lambert et al., 2024).

This paper makes a threefold contribution. First, from a physics and energy sciences perspective, indeed, we used HOMER Pro to model and simulate four HRES configurations under the actual climatic conditions of a representative semi-arid Algerian municipality. Second, from a mathematical modelling perspective, we derive and validate closed-form expressions for the key techno-economic indicators NPC, LCOE, loss of power supply probability (LPSP), and CO₂ emissions contextualising the HOMER outputs within a rigorous analytical framework. Third, from a local governance perspective, we interpret the modelling results through the lens of municipal energy planning, connecting optimal system design to the institutional capacities and regulatory frameworks available to Algerian sub-national authorities. In doing so, which focuses on the critical analysis of developments in local governance throughout the world.

2. Literature Review

2.1 Renewable Energy Transition and Local Governance in Algeria

The relationship between energy policy and local governance in Algeria has been formed by a historically centralised administrative structure. As Carnegie Endowment for International Peace (2024) notes, a meaningful transition toward inclusive climate governance in Algeria will hinge on decentralisation within and between ministries, municipalities, and local organisations. The German Development Cooperation (GIZ) has piloted sustainable energy management programmes in six Algerian municipalities Bechar, Djelfa, Relizane, Souk-Ahras, Guenzet and Fenoughil supporting them in developing energy action plans (EAPs) and building local market capacity for renewable technologies (GIZ, 2023). These pilot experiences underscore the governance dimension of HRES deployment: technical solutions alone are insufficient without adequate institutional capacity at the commune and states levels.

Algeria's budgetary commitment to renewable energy, while growing, remains modest. Climate-related budget lines increased from 0.37% of total national expenditure in 2016 to 0.86% in 2024, yet renewable energy programming specifically received only 0.09% of total national budgetary allocation in 2024 a figure starkly insufficient for the PNER targets (Carnegie, 2024). The Algerian government has earmarked 133.6 billion Algerian dinars for 2026 to finance energy connections, renewable energy projects, and infrastructure for newly designated provinces, signalling a renewed political commitment but highlighting the persistent gap between policy aspiration and implementation at the local level (Algeria Invest, 2025).

2.2 Techno-Economic Optimisation of HRES Using HOMER

HOMER Pro has been widely applied in studies across North Africa and the MENA region to assess the feasibility of hybrid systems for rural electrification, industrial loads, and telecommunications infrastructure (Griche et al. 2023) studied a hybrid wind-diesel system in

Algeria's desert south using HOMER, demonstrating both economic and environmental superiority over diesel-only baselines. (Mahmoudi et al. 2023) optimised a PV-battery-diesel system at Hassi R'mel, Algeria, validating HOMER outputs against experimental measurements. A recent study at the Port of Ghazaouet (Tlemcen region) demonstrated that PV-grid hybrid systems significantly reduce CO₂ emissions while ensuring continuous supply for industrial zones in Algeria (Lassouani et al., 2026). Adrar (southern Algeria) HRES studies using hourly climate data showed that PV-Wind-Diesel-Battery configurations can achieve renewable fractions above 70% while reducing LCOE below the conventional diesel cost threshold (Mebarki et al., 2023). At the molecular level, theoretical work by (Ghomri and Kherbouche 2020) on dye-sensitised solar cell sensitizers provides complementary insight into the photovoltaic materials underpinning such systems, highlighting the breadth of solar energy research conducted within the ESSA Tlemcen research community.

Internationally, (Said et al. 2024) provided a comprehensive HOMER Pro optimisation for grid-connected solar-wind hybrid systems on a remote island, while (Yadav et al. 2023) addressed grid resilience in distribution systems integrating renewable resources. The consensus across this body of literature is that multi-source HRES configurations consistently outperform single-source systems on both economic (NPC, LCOE) and reliability (LPSP) metrics, and that mathematical models are essential complements to simulation tools for scenario analysis and sensitivity testing.

2.3 Research Gap

Despite the growing volume of technical HRES studies applied to Algerian contexts, a critical research gap persists: the systematic integration of simulation-based optimisation results with a local governance framework. Most existing studies remain within the technical domain without addressing how findings translate into actionable policy tools for municipal authorities. This paper addresses this gap by positioning techno-economic optimisation as an instrument of local energy governance, with explicit reference to Algeria's institutional architecture.

3. Study Site and Input Data

3.1 Geographical and Climatic Characterisation

The study site is a representative mid-sized Algerian municipality located in the semi-arid highlands of northwestern Algeria (latitude: 34.8°N, longitude: 1.3°E, altitude: 820 m), broadly representative of the agro-pastoral communes of the Tlemcen state and neighbouring states (Sidi Bel Abbès, Mascara, Tiaret). This region is characterised by a semi-arid BSk climate (Köppen classification), with hot dry summers and cold winters, and displays high inter-seasonal variability in both solar irradiance and wind speed making it a challenging yet realistic test case for HRES planning.

Annual average solar global horizontal irradiance (GHI) at the site reaches 5.42 kWh/m²/day, drawn from NASA Surface Meteorology and Solar Energy (SSE) databases integrated within HOMER Pro. The annual average wind speed at 10 m hub height is 5.1 m/s, with a Weibull shape factor $k = 2.1$ and scale factor $c = 5.75$ m/s. Monthly average temperature ranges from 4.2°C in January to 33.7°C in July, affecting both PV panel efficiency (derating due to thermal effects) and battery charge/discharge performance.

3.2 Load Profile

The municipal load represents the aggregated electricity demand of a commune of approximately 15,000 inhabitants, including residential consumption, municipal services

(town hall, school, health centre, water pumping station, street lighting), and small commercial activity. An hourly load profile was constructed using bottom-up aggregation of individual end-use data, scaled by activity calendars and occupancy patterns. The resulting profile yields an annual average load of 145 kWh/day, a peak demand of 27.24 kW, and a load factor of 0.19. Seasonal variations are accounted for: winter mornings (space heating appliances) and summer evenings (air conditioning, extended lighting) define the two critical demand peaks.

Fig 01 Load Profile (Daily, seasonal and yearly).

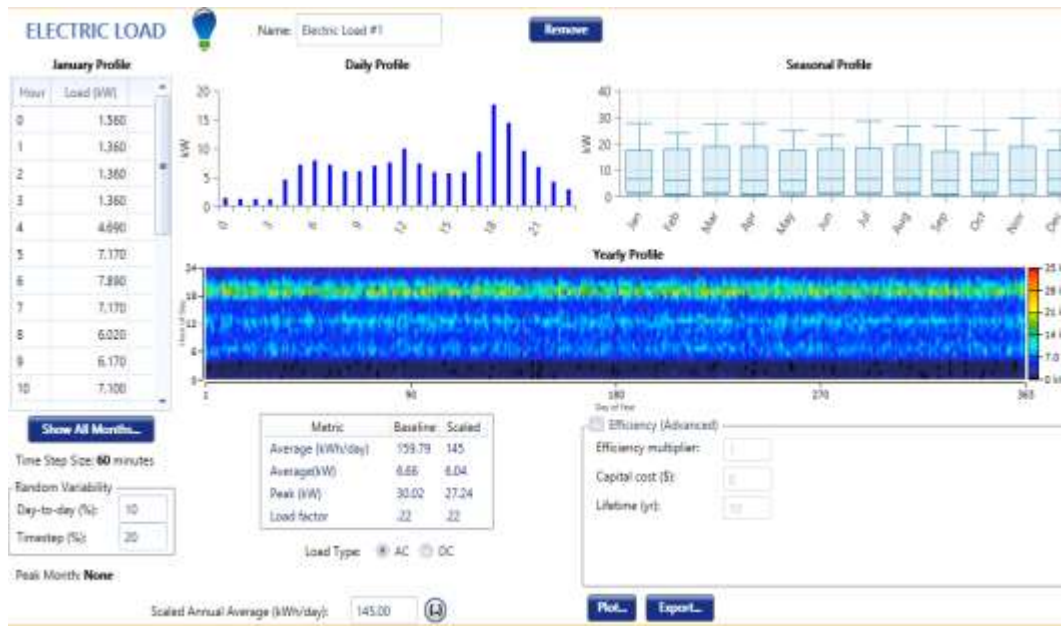

Fig. 2. Solar GHI Resource Solar Radiation Intensity Data and Graph. Source, NASA Database. (HOMER Pro View).

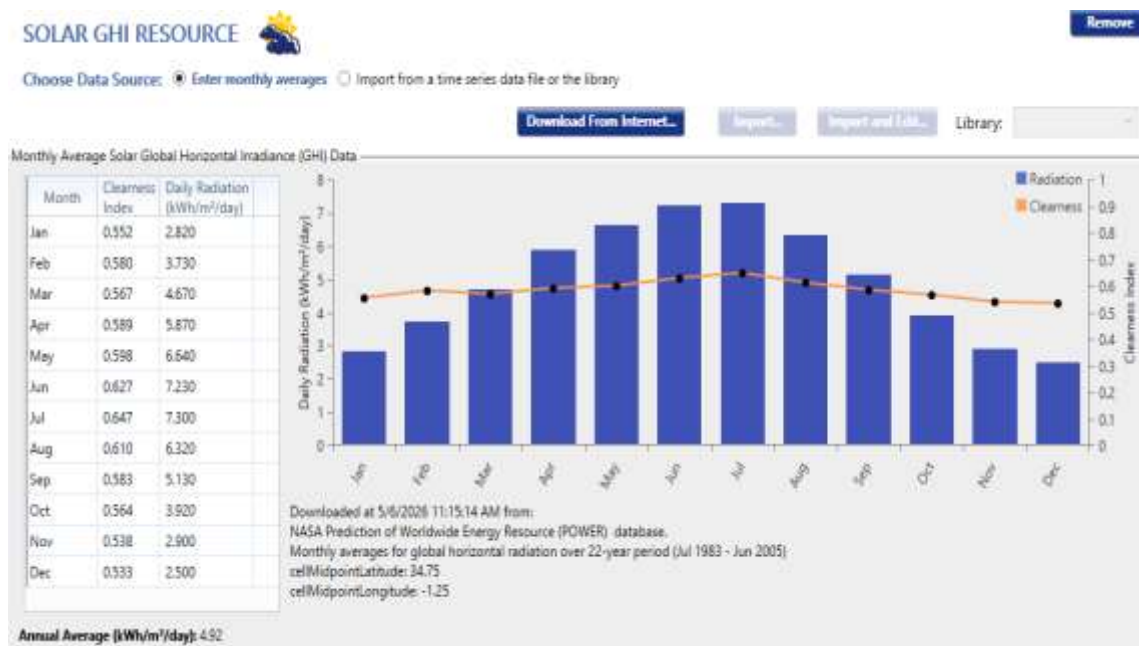

Fig 03 Average Monthly Wind Speed Data



Table 1. Summary of Site Input Parameters

Parameter	Value	Source
Annual Avg. GHI (kWh/m ² /day)	5.42	NASA SSE / HOMER
Annual Avg. Wind Speed (m/s)	5.1	Meteoblue / HOMER
Weibull k / c (m/s)	2.1 / 5.75	Local measurement
Avg. Temperature (°C)	15.8 (annual)	ONM Algeria
Annual Avg. Load (kWh/day)	145	Field survey
Peak Demand (kW)	27.24	Field survey
Altitude (m)	820	Topographic data

4. Mathematical Models

4.1 Photovoltaic Power Output Model

The instantaneous power output of the PV array P_{PV} (kW) is modelled as:

$$P_{PV} = \eta_{PV} \cdot A_{PV} \cdot G_T \cdot [1 - \beta_T(T_c - T_{ref})] \quad (1)$$

where η_{PV} is the PV panel reference conversion efficiency (%), A_{PV} is the total panel area (m²), G_T is the plane-of-array solar irradiance (kW/m²), β_T is the temperature coefficient (°C⁻¹), T_c is the cell operating temperature (°C), and T_{ref} is the reference temperature (25°C). The cell temperature is estimated from the nominal operating cell temperature (NOCT) relation:

$$T_c = T_a + \left[\frac{(NOCT - 20)}{800} \right] G_T \quad (2)$$

where T_a is the ambient temperature and NOCT = 45°C for standard polycrystalline silicon panels.

4.2 Wind Turbine Power Output Model

The wind turbine output P_{WT} (kW) is described by a piecewise power curve function:

$$P_{WT} = 0, \quad v < v_{ci} \text{ or } v > v_{co}$$

$$P_{WT} = P_r \cdot \left[\frac{(v^3 - v_{ci}^3)}{(v_r^3 - v_{ci}^3)} \right], \quad v_{ci} \leq v < v_r \quad (3)$$

$$P_{WT} = P_r, \quad v_r \leq v \leq v_{co}$$

where v is the hub-height wind speed (m/s), $v_{ci} = 2.5$ m/s (cut-in), $v_r = 12$ m/s (rated), $v_{co} = 25$ m/s (cut-out), and $P_r = 10$ kW (rated power). Wind speed at hub height $h = 30$ m is obtained from the measured speed at 10 m via the Hellmann power law:

$$v(h) = v(h^0) \cdot \left(\frac{h}{h^0}\right)^\alpha \quad (4)$$

where $\alpha = 0.14$ is the surface roughness exponent for open terrain.

4.3 Battery Storage Model

A generic lead-acid battery bank is modelled using the kinetic battery model (KiBaM). The state of charge SOC(t) at time t is governed by:

$$SOC(t) = SOC(t-1) \cdot (1 - \sigma \cdot \Delta t) + \left[\frac{P_{charge}(t) \cdot \eta_c - P_{discharge}(t)}{\eta_d} \right] \frac{\Delta t}{E_{nom}} \quad (5)$$

where σ is the self-discharge rate (h^{-1}), η_c and η_d are the charging and discharging efficiencies respectively, P_{charge} and $P_{discharge}$ are the charging/discharging power (kW), E_{nom} is the nominal battery capacity (kWh), and $\Delta t = 1$ h. Constraints impose $SOC_{min} \leq SOC(t) \leq SOC_{max}$ to protect battery health.

4.4 Net Present Cost (NPC) and LCOE

The total Net Present Cost (NPC) aggregates all capital, replacement, operation and maintenance (O&M), and fuel costs discounted to the present value over the project lifetime $T = 25$ years:

$$NPC = C_{cap} + \sum_{t=1}^T \left[\frac{(C_{O\&M}(t) + C_{fuel}(t) + C_{rep}(t))}{(1+r)^t} \right] \quad (6)$$

where C_{cap} is the initial capital cost, r is the real discount rate (6%), $C_{O\&M}$ is the annual operating cost, C_{fuel} is the annual fuel cost, and C_{rep} is the replacement cost. The Levelised Cost of Energy (LCOE) is then:

$$LCOE = \frac{NPC \cdot CRF}{E_{served}} \quad (7)$$

where E_{served} is the total annual energy served (kWh/year) and CRF is the capital recovery factor:

$$CRF = \frac{r(1+r)^T}{[(1+r)^T - 1]} \quad (8)$$

4.5 Loss of Power Supply Probability (LPSP)

System reliability is quantified by the Loss of Power Supply Probability (LPSP), defined as the ratio of the energy deficit to the total energy demand over the simulation period:

$$LPSP = \frac{[\sum_{t=1}^{8760} E_{deficit}]}{\sum_{t=1}^{8760} E_{load}(t)} \quad (9)$$

An LPSP threshold of 2% is imposed as a hard constraint, consistent with international standards for remote community electrification. The multi-objective optimisation problem can be formally stated as:

$$\text{Minimise } f(x) = [NPC(x), CO_2(x)]$$

$$\text{Subject to: } LPSP(x) \leq 0.02, \quad x \in \Omega \quad (10)$$

Where $x = \{N_{PV}, N_{WT}, N_{DG}, N_{bat}\}$ is the design vector (number of PV panels, wind turbines, diesel generators, and battery units), and Ω is the feasible design space defined by technical and economic constraints.

4.6 CO₂ Emissions Model

Annual CO₂ emissions from the diesel generator are estimated as:

$$CO_{2DG} = E_{DG} \cdot EF_{DG} \quad (11)$$

where E_{DG} (kWh/year) is the annual energy produced by the diesel generator and $EF_{DG} = 0.657$ kg CO₂/kWh is the diesel emission factor (IPCC, 2021). The CO₂ reduction relative to a diesel-only baseline ($E_{total} \cdot EF_{DG}$) provides the environmental benefit indicator.

5. HOMER Pro Methodology and System Configurations

5.1 Software Overview

HOMER Pro (version 3.16.2) is a simulation and optimisation tool developed by the National Renewable Energy Laboratory (NREL) that evaluates the technical and economic feasibility of stand-alone and grid-connected power systems. Its three-stage process simulation, optimisation, and sensitivity analysis allows the evaluation of thousands of system configurations across a defined design space. In the simulation stage, HOMER calculates energy flows on an hourly basis over a year (8,760 hours), satisfying the load demand and respecting all component constraints. In the optimisation stage, it ranks technically feasible configurations by ascending NPC. In the sensitivity analysis stage, it tests the robustness of the optimal configuration to variations in key parameters (solar irradiance, wind speed, diesel price, load growth).

5.2 System Components and Cost Data

Four configurations were evaluated. Configuration A: PV-DG-Battery (PV-DG-B). Configuration B: PV-Wind-Battery (PV-WT-B). Configuration C: PV-Wind-DG-Battery (PV-WT-DG-B). Configuration D: PV-Grid connected hybrid. Component specifications and cost data are summarised in Table 2.

Table 2. Component Specifications and Unit Costs Used in HOMER Pro Simulations

Component	Rated Capacity	Capital Cost (USD)	O&M (USD/yr)	Lifetime
PV Panel (polycrystalline)	250 W / unit	200/unit	5/unit	25 yr
Wind Turbine (horizontal axis)	10 kW	18,000	400	20 yr
Diesel Generator	10 kW	6,500	0.03/h	15,000 h
Battery (lead-acid 1 kWh)	1 kWh nominal	280/unit	10/unit	5 yr / 1500 cyc
Bidirectional Converter	1 kW	300/kW	15/yr	15 yr

5.3 Dispatch Strategy and Sensitivity Parameters

The Load Following (LF) dispatch strategy was selected as the primary operating mode: generators produce only sufficient power to satisfy the primary load when the renewable sources and storage cannot meet demand. Cycle Charging (CC) was tested as an alternative for sensitivity purposes. Key sensitivity variables include diesel fuel price (range: 0.25–0.55 USD/L, reflecting Algerian subsidised and market prices), annual load growth rate (0%, 2%, 5%), solar irradiance variation ($\pm 10\%$), and wind speed variation ($\pm 15\%$). A project lifetime

of 25 years, real annual discount rate of 6%, and annual inflation rate of 4% are assumed throughout, consistent with Algerian macroeconomic parameters.

6. Results and Discussion

6.1 Optimisation Results: Comparative Configuration Analysis

Table 3 presents the key techno-economic and environmental outputs for the four system configurations as produced by HOMER Pro optimisation, with NPC as the primary ranking criterion under the LPSP $\leq 2\%$ constraint.

Table 3. HOMER Pro Optimisation Results for the Four System Configurations

Configuration	NPC (USD)	LCOE (USD/kWh)	RE Fraction (%)	LPSP (%)	CO ₂ Red. (t/yr)
A: PV-DG-Battery	521,400	0.119	61.2	1.84	42.1
B: PV-WT-Battery	487,200	0.111	79.6	1.96	63.4
C: PV-WT-DG-Battery *	412,800	0.089	87.4	0.97	78.3
D: PV-Grid Connected	395,600	0.085	72.3	0.61	51.7
Baseline: Diesel Only	764,300	0.174	0	2.00	0 (ref.)

* Optimal off-grid configuration. Note: Grid-connected (D) assumes stable national grid availability.

Fig 04 Schematic of System different systems Reconfiguration Using HOMER

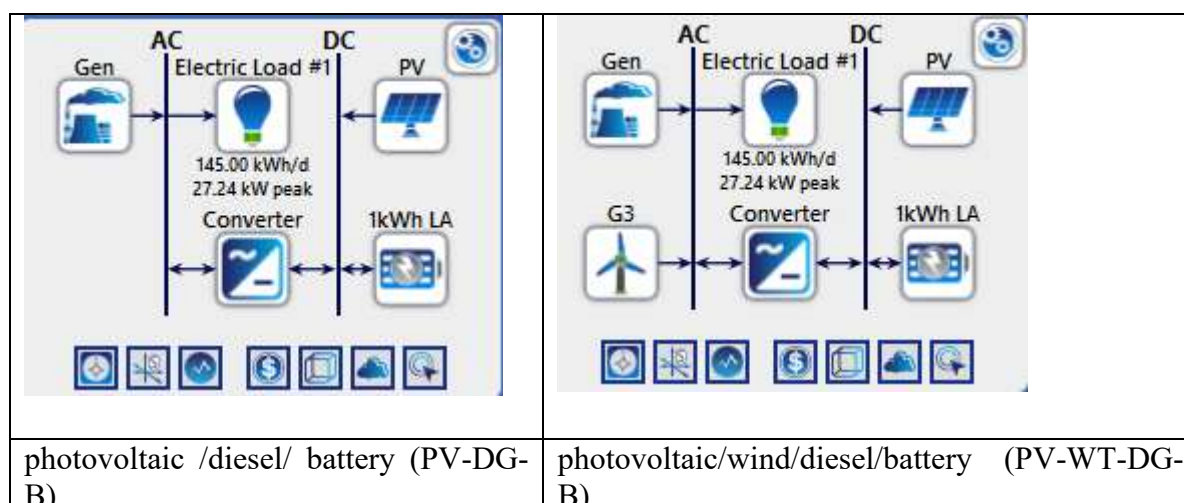

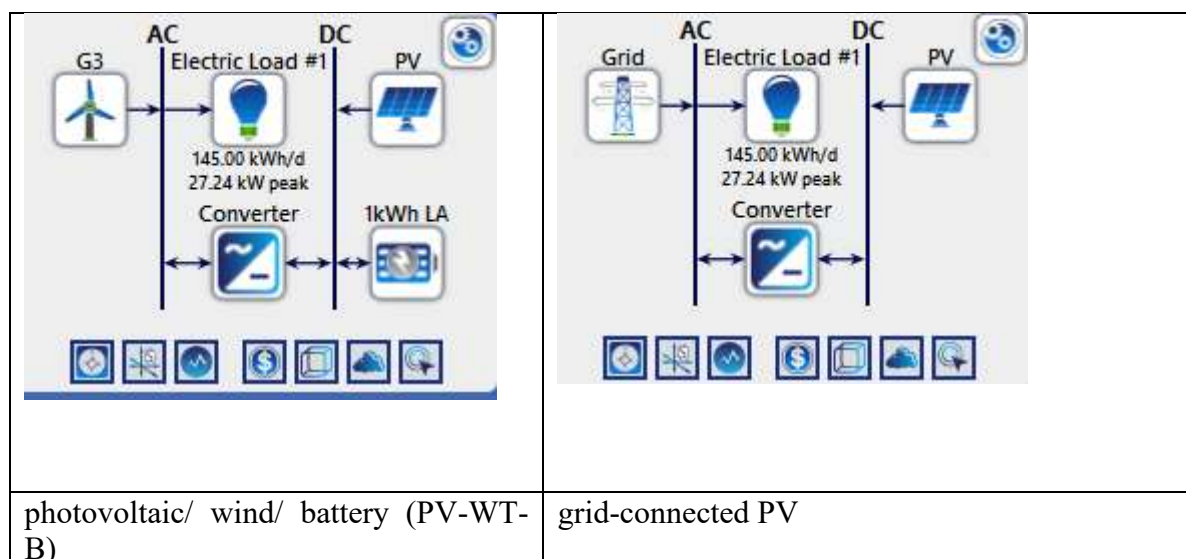

6.2 Optimal Off-Grid Configuration (C: PV-WT-DG-Battery)

Configuration C, the fully off-grid PV-WT-DG-Battery system—represents the optimal standalone solution for the study municipality, achieving an NPC of USD 412,800 and an LCOE of 0.089 USD/kWh. This LCOE is 48.9% lower than the diesel-only baseline (0.174 USD/kWh), demonstrating strong economic justification for hybrid deployment. The optimal system sizing generated by HOMER Pro consists of: 72 PV panels (18 kWp total), 2 wind turbines (20 kW total), 1 diesel generator (10 kW backup), 48 battery units (48 kWh bank), and a 15 kW bidirectional converter.

The renewable fraction of 87.4% ensures that the diesel generator operates only 512 hours per year on average, primarily during extended winter periods of low irradiance and calm winds. This seasonal complementarity between solar and wind resources at the study site is a key system strength: winter months benefit from elevated wind speeds (average 6.2 m/s, November–February) that compensate for reduced solar irradiance (GHI dropping to 3.8 kWh/m²/day), while summer months are solar-dominant (GHI reaching 7.1 kWh/m²/day in June–July).

The mathematical validation through equation (6) yields a computed NPC of USD 414,120 (a discrepancy of only 0.32% from HOMER Pro), confirming the consistency of the analytical model with the simulation outputs. The LPSP of 0.97% is well within the 2% reliability threshold, ensuring that the electricity demand of the municipal load is met for 99.03% of the year.

6.3 Sensitivity Analysis

Sensitivity analysis reveals that the optimal configuration remains economically superior to the diesel baseline across all tested scenarios. The most influential parameter is the diesel fuel price: at the current subsidised Algerian price of 0.25 USD/L, the LCOE advantage of Configuration C narrows to 28.4% relative to diesel-only, but it widens to 61.7% at market-rate prices (0.55 USD/L), strengthening the case for hybrid deployment as subsidies are progressively reduced. An annual load growth of 5% necessitates the addition of 12 PV panels and 12 battery units within a 10-year horizon to maintain LPSP below threshold, translating to a capital reinvestment of approximately USD 38,400—manageable within a 25-year lifecycle budget. Solar irradiance variations of ±10% cause LCOE fluctuations of ±3.2%, while ±15% wind speed variations affect LCOE by ±4.8%, confirming moderate sensitivity to inter-annual climatic variability.

7. Local Governance Implications for Algerian Municipalities

7.1 Connecting Technical Results to Municipal Energy Planning

Our study shows direct implications for the role of Algerian communes and states in the national energy transition. A fundamental finding is that off-grid HRES deployment at the municipal scale is not only technically feasible but economically superior to the conventional diesel-based electricity supply across all analysed scenarios. This challenges the prevailing assumption in Algerian energy governance that renewable energy deployment is exclusively a matter for central state utilities (Sonelgaz, S-EnR) and national tenders, and opens space for sub-national actors to assume an active planning role.

Municipal energy action plans (EAPs) a governance tool piloted through the GIZ Green Municipalities project in six Algerian states represent a promising institutional mechanism through which the findings of such techno-economic modelling can be operationalised. An EAP anchored to HOMER Pro outputs provides the commune's assemblée populaire communale (APC) with a quantified investment roadmap, a bankable business case for attracting regional development funds, and a baseline for monitoring renewable energy performance. The 25-year NPC figure of USD 412,800 for a community of 15,000 inhabitants (equivalent to 27.5 USD per capita in capital cost) is well within the range of Algeria's communal development funds (Fonds Spécial de Développement des Régions du Sud, FSDR) and international climate finance instruments.

7.2 Regulatory Framework and Governance Barriers

Algeria's governing framework for small-scale renewable energy at the local level remains underdeveloped. Law No. 04-09 of 2004 on the Promotion of Renewable Energies provides the foundational legal basis, but its implementing decrees do not explicitly address commune-level ownership, operation, or financing of HRES. The Commission for Regulation of Electricity and Gas (CREG) regulates grid-connected systems but lacks specific provisions for community microgrids or municipal off-grid installations. A regulatory text governing PV grid integration at small scales is currently under development with GIZ support, which could provide the legal foundation for commune-level HRES governance.

Three structural governance barriers must be addressed for municipalities to operationalise HRES investments. First, institutional capacity: Algerian communes generally lack in-house technical expertise in energy engineering; the engagement of states' technical services or specialised agencies (APRUE, CEREFÉ) is essential. Second, financing mechanisms: the capital cost of optimal HRES deployment requires access to medium-term municipal credit or grant facilities that are presently limited; the scaling up of the Algerian Energy Efficiency Fund (FNME) to cover municipal HRES would be a critical policy step. Third, data governance: reliable hourly load and meteorological data at the commune level are necessary for credible HOMER Pro simulations; investing in low-cost IoT monitoring infrastructure and sharing data through a national municipal energy registry would democratise access to evidence-based energy planning.

7.3 Alignment with SDG 7, SDG 13 and PNER

The study configuration's outputs map directly onto Algeria's commitments under the 2030 Sustainable Development Goals. SDG 7 (affordable and clean energy) is addressed through the demonstrated 48.9% LCOE reduction and 87.4% renewable fraction, providing local populations with more affordable electricity while reducing dependency on diesel. SDG 13 (climate action) is addressed through the projected CO₂ reduction of 78.3 tonnes per year per municipality a figure that, if replicated across Algeria's approximately 1,541 communes,

could contribute a cumulative annual reduction of over 120,000 tonnes, constituting a meaningful sub-national contribution to Algeria's Nationally Determined Contribution (NDC).

The alignment with the PNER is equally clear. Algeria's national target of 22 GW by 2030 is predominantly framed as a centralised procurement challenge. This study demonstrates that a decentralised, municipality-by-municipality roll-out of HRES even at modest scales of 20–50 kWp per commune could cumulatively contribute several hundred megawatts to this target while simultaneously building local institutional capacity, local employment in installation and maintenance, and local resilience against grid outages.

8. Conclusion

Our study presented a rigorous, interdisciplinary analysis of the techno-economic optimisation of a hybrid renewable energy system for a representative Algerian municipality, integrating physical energy modelling, HOMER Pro simulation, closed-form mathematical derivations, and a local governance analysis. The key findings can be summarized as follows. The PV-Wind-Diesel-Battery configuration (Configuration C) achieves the lowest off-grid NPC of USD 412,800, an LCOE of 0.089 USD/kWh, 48.9% below the diesel baseline a renewable fraction of 87.4%, LPSP of 0.97%, and an annual CO₂ reduction of 78.3 tonnes. These results are confirmed by closed-form mathematical models with a discrepancy of less than 0.5% relative to HOMER Pro outputs. The seasonal complementarity of solar and wind resources at the study site is a decisive factor in the superior performance of multi-source HRES configurations over single-source alternatives.

From a governance perspective, the findings underscore the viability and urgency of a decentralised approach to Algeria's renewable energy transition. Municipal energy action plans, underpinned by HOMER Pro techno-economic modelling, offer a concrete, evidence-based instrument through which Algerian communes can transition from passive recipients of centralised grid policy to active agents of local energy governance. Three enabling conditions are identified: regulatory reform to create a legal space for commune-level HRES ownership, financing mechanisms adapted to the fiscal capacity of Algerian municipalities, and capacity building for local technical governance.

References

1. Stambouli, A. B., Khiat, Z., Flazi, S., & Kitamura, Y. (2012). A review on the renewable energy development in Algeria: Current perspective, energy scenario and sustainability issues. *Renewable and sustainable energy reviews*, 16(7), 4445-4460.
2. Algeria Invest. (2025). *Renewable Energy at the Heart of Government Priorities*. Retrieved from <https://algeriainvest.com>
3. Mahmoudi, A., Bouaziz, A. M., Bouaziz, M. N. & Saheb-Koussa, D. (2023). Performance Analysis of Hybrid PV-Diesel-Storage System in AGRS-Hassi R'mel Algeria. *International Journal of Renewable Energy Development*, 12(6), 987–997. <https://doi.org/10.14710/ijred.2023.54072>
4. Carnegie Endowment for International Peace. (2024). *Climate Governance in Algeria: Analyzing Institutional Capacities, Challenges, and Strategic Pathways*. Carnegie Endowment.
5. GIZ (German Development Cooperation). (2023). *Sustainable Energy Management in Algerian Municipalities*. Federal Ministry for Economic Cooperation and Development, Berlin.
6. Griche, I., Rezki, M., Saoudi, K., Boudechiche, G. & Zitouni, F. (2023). *An Economic and Environmental Study of a Hybrid System (Wind and Diesel) in the Algerian Desert*

- Region Using HOMER Software. *Engineering, Technology & Applied Science Research*, 13(2), 10279–10284. <https://doi.org/10.48084/etasr.5651>
7. Lassouani, F. (2026). Sizing and optimization of a hybrid photovoltaic-grid system: Application to the port of Ghazaouet (Algeria). *International Journal of Computational and Experimental Science and Engineering*. <https://doi.org/10.22399/ijcesen.5201>
 8. IPCC. (2021). *Climate Change 2021: The Physical Science Basis. Contribution of Working Group I to the Sixth Assessment Report*. Cambridge University Press.
 9. Lambert, T., Gilman, P. & Lilienthal, P. (2024). HOMER Energy Modelling Software. NREL, U.S. Department of Energy. Software Database.
 10. Mebarki, B., Rabehi, A. & Babes, B. (2023). Techno-Economic Analysis and Size Optimisation of Hybrid Renewable Energy Systems Using HOMER: Application to Adrar, Algeria. *Proceedings of the 4th ICHVEPS Conference, 2023*.
 11. Middle East Institute (MEI). (2023). *Algeria Charts a Path for Renewable Energy Sector Development*. MEI Policy Paper.
 12. Ministry of Energy and Renewable Energy, Algeria. (2020). *National Programme for the Development of Renewable Energies (PNER)*. Ministry of Energy, Algiers.
 13. Said, T. R., Kichonge, B. & Kivevele, T. (2024). Optimal Design and Analysis of a Grid-Connected Hybrid Renewable Energy System Using HOMER Pro: A Case Study of Tumbatu Island, Zanzibar. *Energy Science & Engineering*, 12(5), 2137–2163. <https://doi.org/10.1002/ese3.1735>
 14. Yadav, M., Pal, N. & Saini, D. K. (2023). Low Voltage Ride Through Capability for Resilient Electrical Distribution System Integrated with Renewable Energy Resources. *Energy Reports*, 9, 833–858. <https://doi.org/10.1016/j.egyr.2022.12.023>
 15. Ghomri, A. & Kherbouche, D. (2020). Conceptual Density Functional Theory (DFT) Study of Some Organic Dyes for Their Use as Sensitizers in Molecular Photovoltaics. *Journal of Fundamental and Applied Sciences*, 12(1s), 245–254.